

MTX

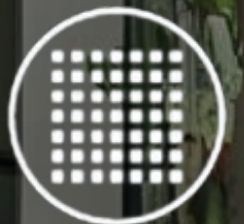

EXCELENCIA E INNOVACIÓN



INTI



**SOLUCIONES EN ALUMINIO PARA UN
MUNDO DE POSIBILIDADES.**

 @MTXPERFILES

 mtxperfiles.com/



+54 9 11 2699-6231
+54 9 11 3081-9410
+54 9 11 5338-8537



INDICE:

	Página
Línea Herrero	1
Línea Modena	9
Línea A30	15



LÍNEA HERRERO



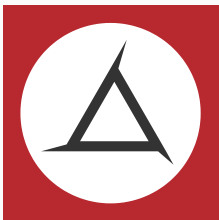





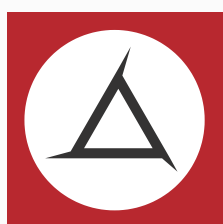



Línea Herrero

Código	Forma	Descripción	
KS -001		Marco de Corrediza	0,930
KS -002		Cabezal / Zócalo de Hoja	0,502
KS -003		Parante Lateral Hoja Corrediza	0,563
KS -004		Parante Central Hoja Corrediza	0,497
KS -012		Guía de Cortina	0,346
KS -015		Tapacintas Pesado	0,480
KS -016		Escuadra Universal 13 mm.	0,780
KS -017		Umbral Puerta de Balcón	1,050
KS -018		Perimetral VRP Rayado	0,205

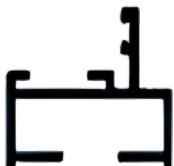

Línea Herrero

Código	Forma	Descripción	Peso Kg/M
KS -019		Nudo VRC Rayado con Cava	0,348
KS -022		Perimetral VRP Liso Chico	0,239
KS -023		Nudo VRC Liso Chico con Cava	0,331
KS -027		Escuadra 2001 Liviana	0,350
KS -028		Parante de Postigón Chico	0,495
KS -029		Parante de Postigón Grande	0,622
KS -030		Marco de Postigón Chico	0,340
KS -031		Marco de Postigón Grande	0,560
KS -032		Nudo VRC Rayado con Cava	0,348

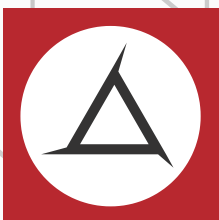

Línea Herrero

Código	Forma	Descripción	Peso Kg/M
KS -034		U de Armado 75 x 25	0.613
KS -039		Parante de puerta 36	0,910
KS -040		Parante de puerta 36 armado a 45°	0,950
KS -041		Marco Puerta de 36	0,580
KS -042		Travesaño puerta de 36	0,997
KS -045		Marco Postizo Corrediza	0,441
KS -046		Revestimiento Acanalado 5 mm.	0,514
KS -047		Revestimiento Acanalado 9 mm.	0,577
KS -048		Revestimiento Tubular	0,920

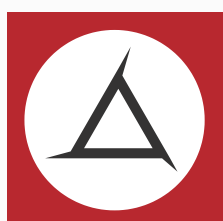

Línea Herrero

Código	Forma	Descripción	Peso Kg/M
KS -053		Marco Aireador c/Aleta y Mosq.	0.472
KS -056		Marco de 4 Guías	1,155
KS -058		Marco de Puerta Placa 75 mm.	0,514
KS -060		Tablilla Curva de Postigón	0,288
KS -064		Parante Chico Postigón c/V Rep.	0,488
KS -065		Marco de Corrediza Liviano Recto	0,530
KS -066		Perfil de Unión Vista Ancha	0,393
KS -067		Marco Corrediza c/Contramarco	0,748
KS -075		Marco de Pta. de Rebatir	0,748



Línea Herrero

Código	Forma	Descripción	Peso Kg/M
KS -090		Travesaño Hoja Mosquitero	0.486
KS -108		Marco a 45° para Escuadra	0,351
KS -109		Marco de Puerta Placa 41 mm.	0,488
KS -121		Marco de Corrediza Liviano	0,556
KS -153		Parante Lateral Reforzado	0,695
KS -154		Parante Central Reforzado	0,669
KS -155		Travesaño	0,672
KS -156		Contravidrio Universal	0.215
KS -159		Escuadra Reforzada	0,510



Línea Herrero

Código	Forma	Descripción	Peso Kg/M
KS -902		Cabezal / Zócalo de Hoja	0,432
KS -903		Parante Lateral Hoja Corrediza	0,463
KS -904		Parante Central Hoja Corrediza	0,420
KS -905		Mosquitero	0,320
KS -907		Marco Paño Fijo	0,525
KS -908		Contravidrio Recto	0,168
KS -911		Guía de Cortina Común	0,358
KS -914		Tapacintas Liviano	0,334
KS -944		Zócalo	0,753

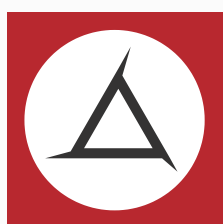

Línea Herrero









Código	Forma	Descripción	Peso Kg/M
KS -901		Premarco 73	0,575
KS -906		Marco Perimetral Corrediza 45°	1,183
KS -907		Complemento Parante Central 45°	0,381
KS -908		Hoja Vidrio Simple 45°	0,821
KS -909		Hoja Vidrio DVH 45°	0,794

LÍNEA MODENA





Línea Modena

Código	Forma	Descripción	Peso Kg/M
KS -200		Umbral / Dintel Marco	1,266
KS -201		Jambas Marco de Corrediza	0,662
KS -203		Parante Lateral Hoja Simple	0,651
KS -204		Cabezal/Zócalo Hoja Simple	0,705
KS -205		Premarco	0,383
KS -206		Contramarco	0,184
KS -207		Parante Central Hoja Simple	0,613
KS -209		Hoja Alta Zocalo Puerta Corrediza	1,256
KS -210		Marco Ventana	0,786



Línea Modena

Código	Forma	Descripción	Peso Kg/M
KS -212		Contravidrio recto 36 mm,	0,313
KS -213		Acople Marco	0,257
KS -214		Parante	1,088
KS -215		Hoja recta vent. abr. doble cont./band.	0,861
KS -216		Marco	0,726
KS -217		Contravidrio Recto	0,292
KS -218		Travesaño	1,085
KS -219		Zocalo Hoja Puerta Rebatir	1,647
KS -220		Contravidrio Exterior	0,176











Línea Modena

Código	Forma	Descripción	Peso Kg/M
KS -221		Travesaño Angosto Paño Fijo	0,767
KS -224		Enc. Cent. Ventana de Abrir 2 Hojas	0,780
KS -225		Contravidrio Recto 22 mm.	0,310
KS -226		Contravidrio Recto 15 mm.	0,211
KS -227		Hoja de Ventiluz Recta	0,864
KS -228		Tope de Mosquitero	0,186
KS -229		Marco Curvo	0,764
KS -230		Contravidrio Curvo 29 mm.	0,213
KS -231		Contavidrio DVH	0,159







Línea Modena

Código	Forma	Descripción	Peso Kg/M
KS -232		Contravidrio curvo 22 mm.	0,159
KS -233		Contravidrio curvo 8 mm.	0,135
KS -235		Hoja Curva Ventana de Abrir DC y Ventana Banderola	0,902
KS -237		Contravidrio Portafelpa.	0,181
KS -240		Umbral y Dintel 3 Guías	1,652
KS -241		Jamba Marco 80	0,969
KS -248		Parante Lateral DVH	0,608
KS -249		Cabezal/Zócalo DVH	0,632
KS -250		Parante Central DVH	0,567



Línea Modena

Código	Forma	Descripción	Peso Kg/M
KS -252		Hoja Alta Zócalo pta. corr. DVH	1,188
KS -253		Travesaño Hoja DVH pta. Corrediza	0,640
KS -257		Contravidrio Curvo 36 mm.	0,235
KS -259		Marco de Ventana Proyectante	0,748
KS -264		Travesaño para Paño Fijo Curvo	0,713

LÍNEA A30





Línea A30

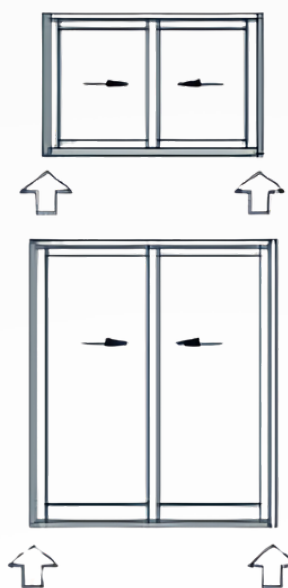
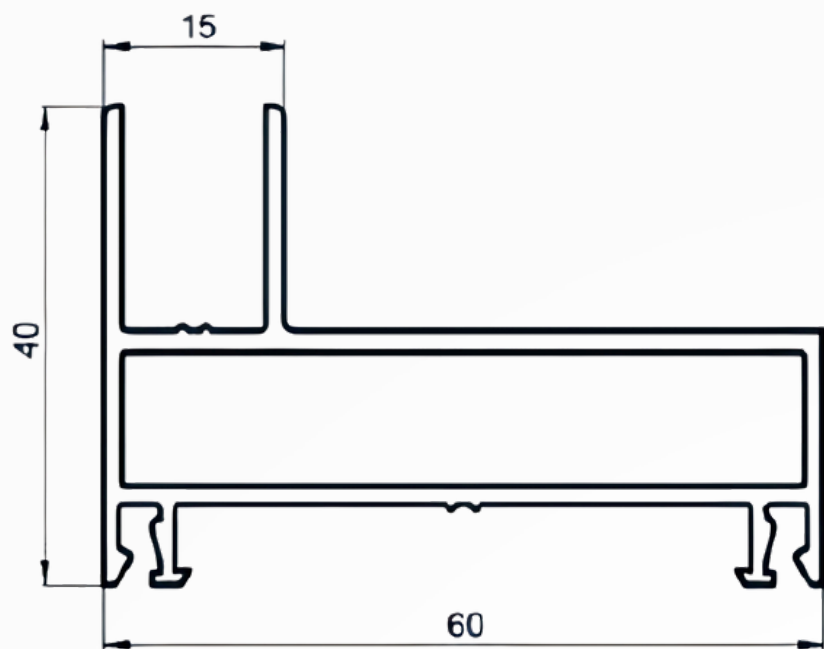

KS
636

Jamba A30
(0,891 kg/m)
Tiras por Paquete 2

KS
637

Umbral y Dintel Corredizo
(1,744 kg/m)
Tiras por Paquete 2

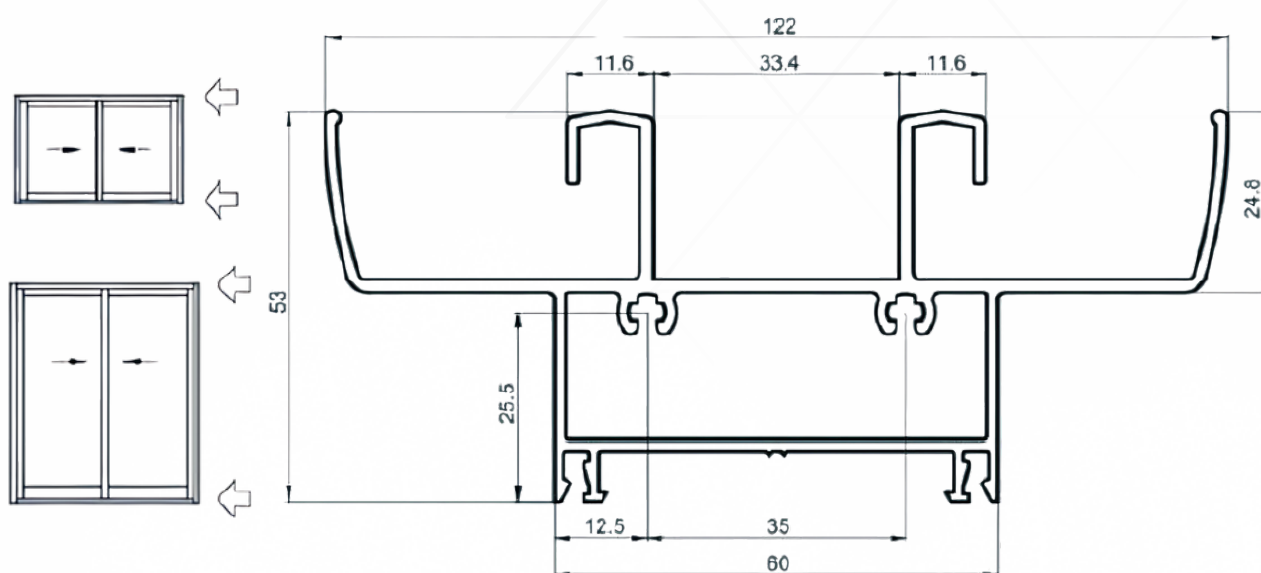

KS
652

Hoja Borde Curvo Ventana de Abrir

(1,139 kg/m)
Tiras por Paquete 2

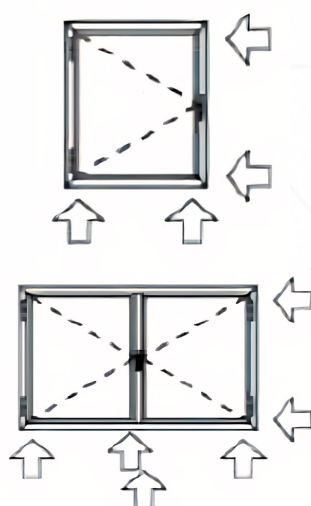
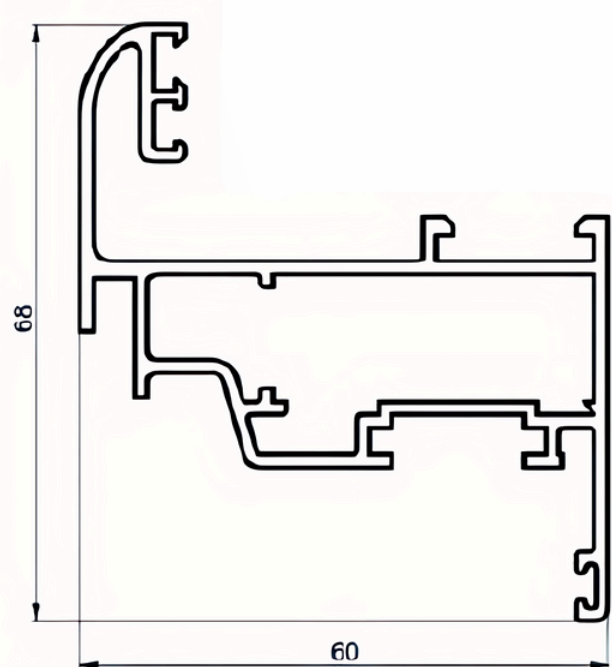



Línea A30

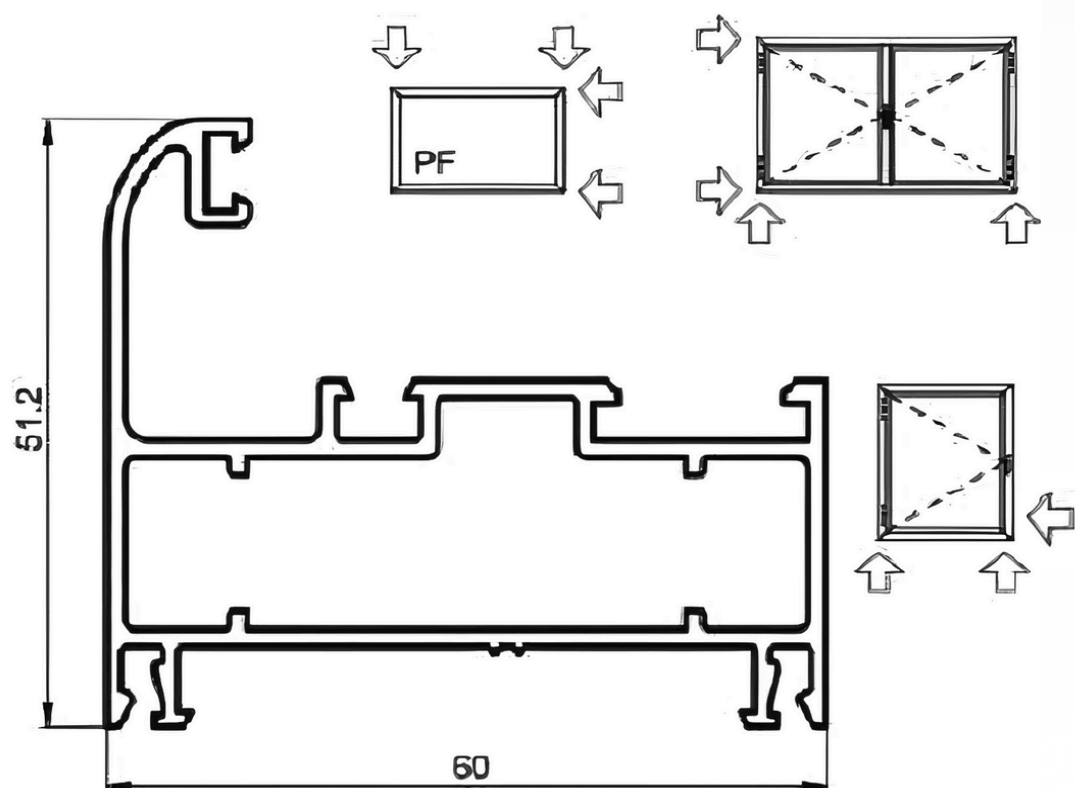

KS
659

**Marco Borde Recto
Ventana de Abrir y
Paño Fijo**

(1,037 kg/m)
Tiras por Paquete 2

KS
659

**Marco Borde Recto
Ventana de
Abrir y Paño Fijo**

(1,053 kg/m)
Tiras por Paquete 2

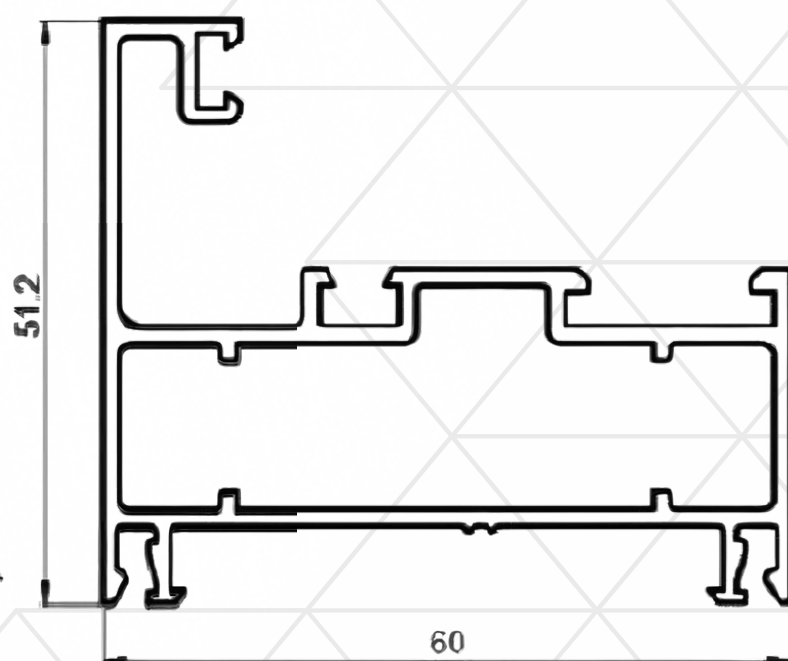
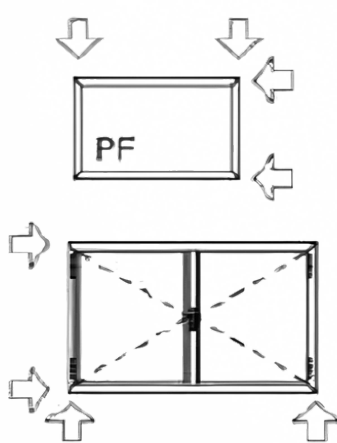

KS
660

**Travesaño
Paño Fijo**

(1,091 kg/m)
Tiras por Paquete 3

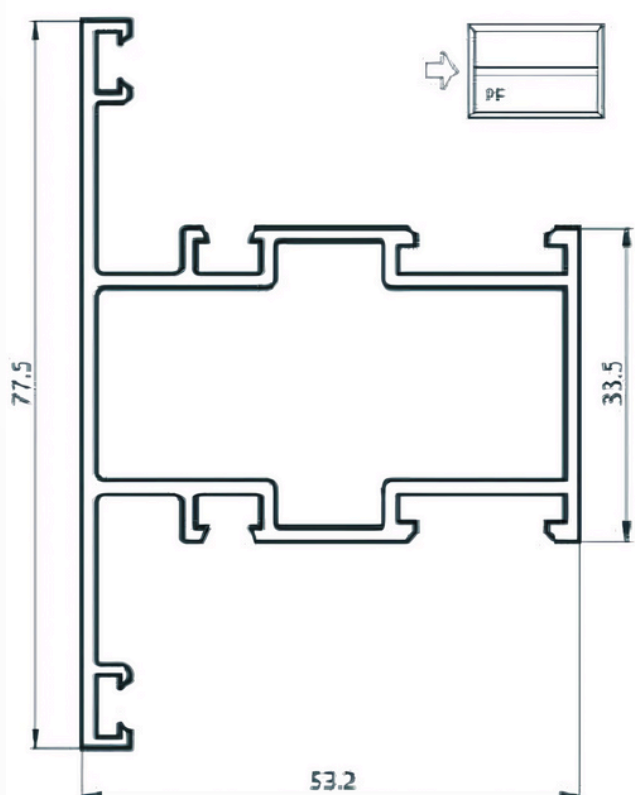

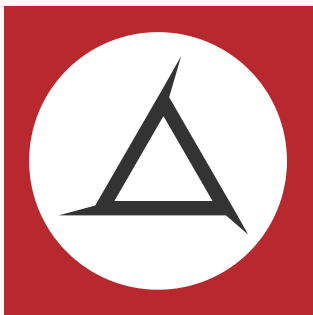

Línea A30

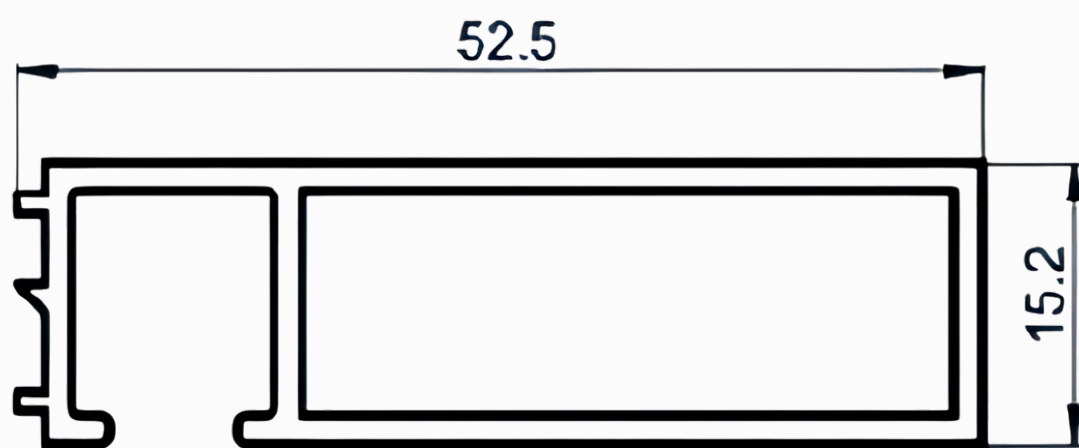

KS
666

Premarco

(0,545 kg/m)
Tiras por Paquete 10

KS
667

Acople

(0,329kg/m)
Tiras por Paquete 10

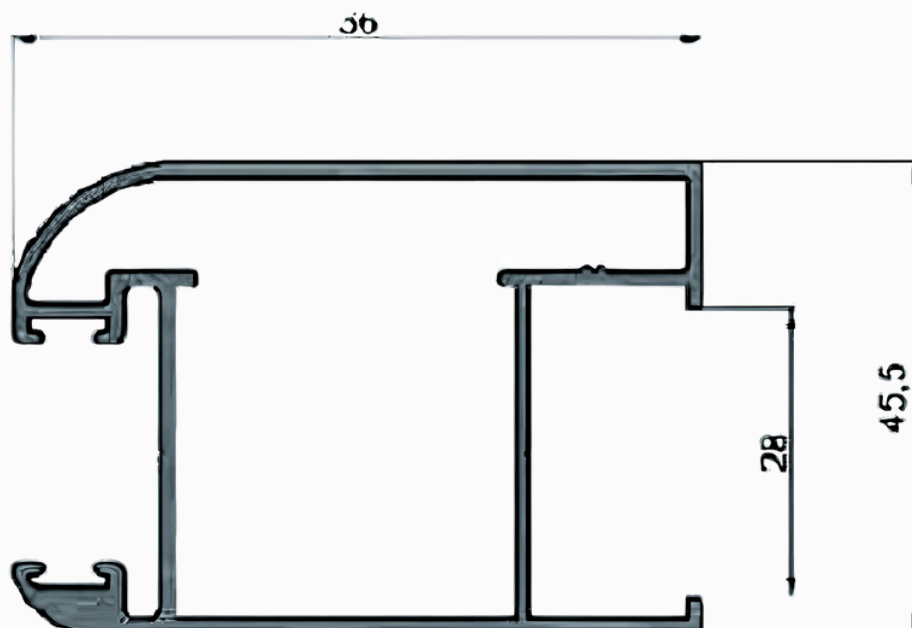
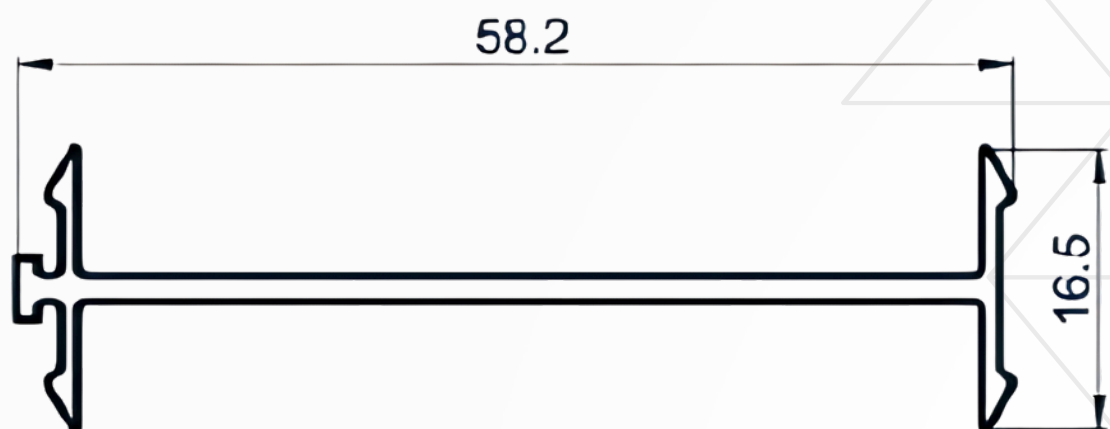

KS
671

Parante Lateral DVH

(1,144 kg/m)
Tiras por Paquete 2

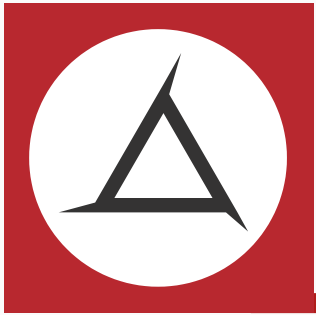

Línea A30

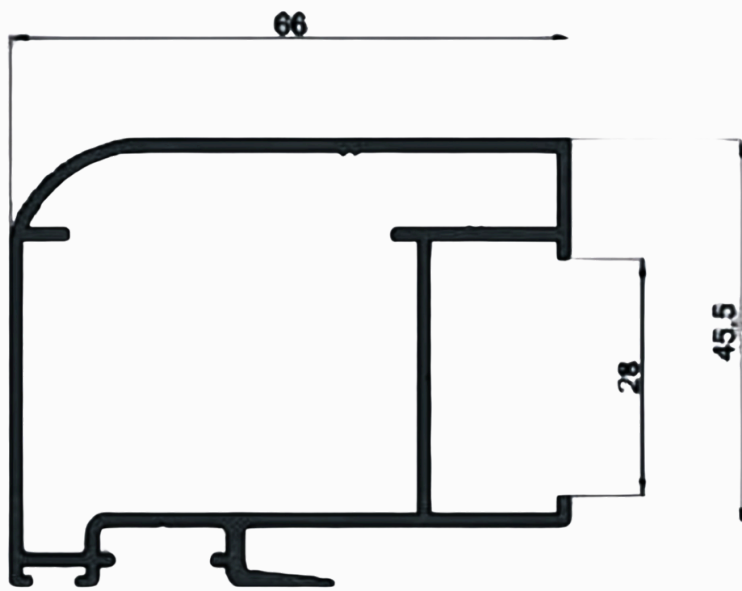

KS
682

Parante Central DVH

(1,144 kg/m)
Tiras por Paquete 2

KS
965

Encuentro de 4 Hojas

(0,329kg/m)
Tiras por Paquete 10

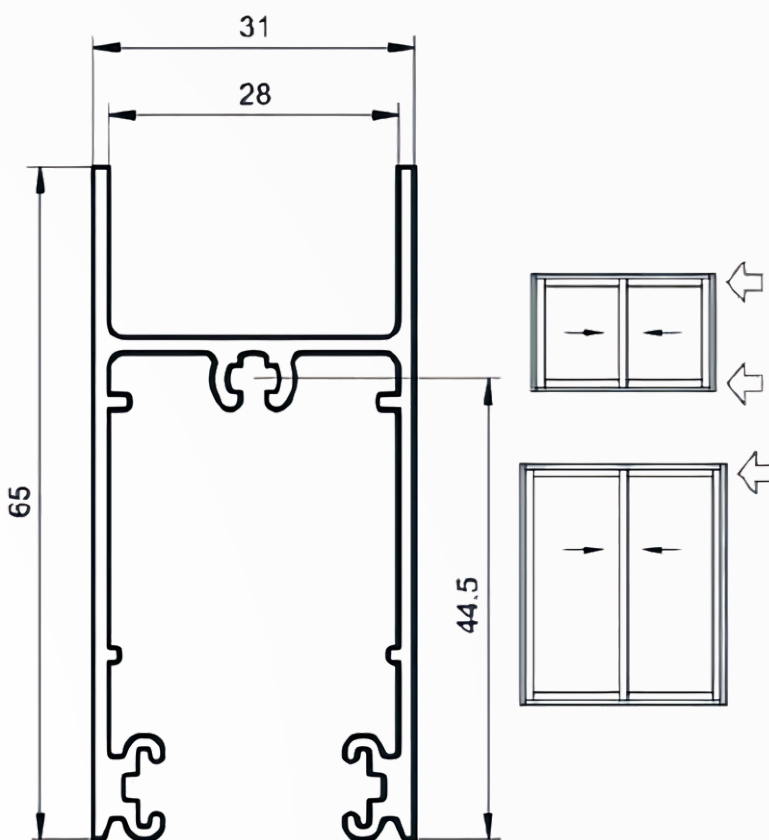
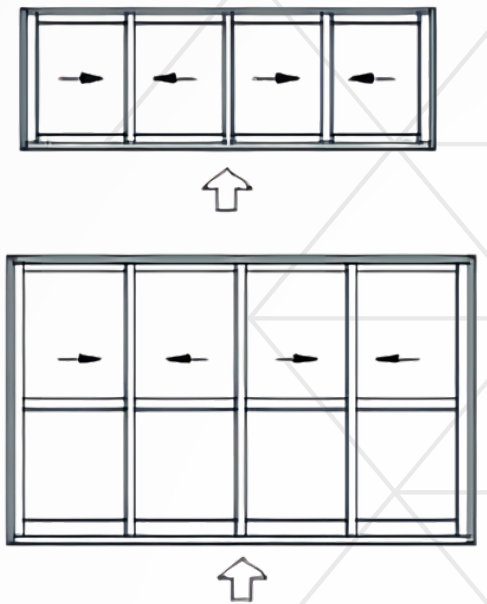
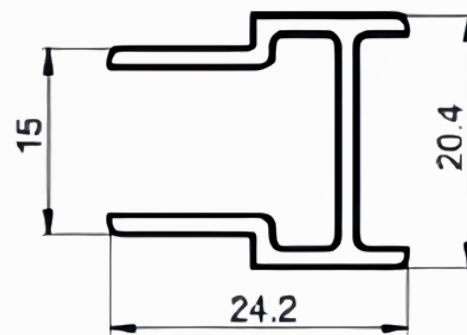

KS
673

Zocalo Corrediza DVH

(0,881 kg/m)
Tiras por Paquete 4

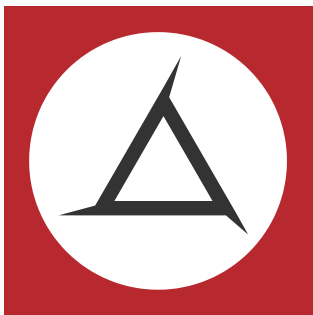

Línea A30

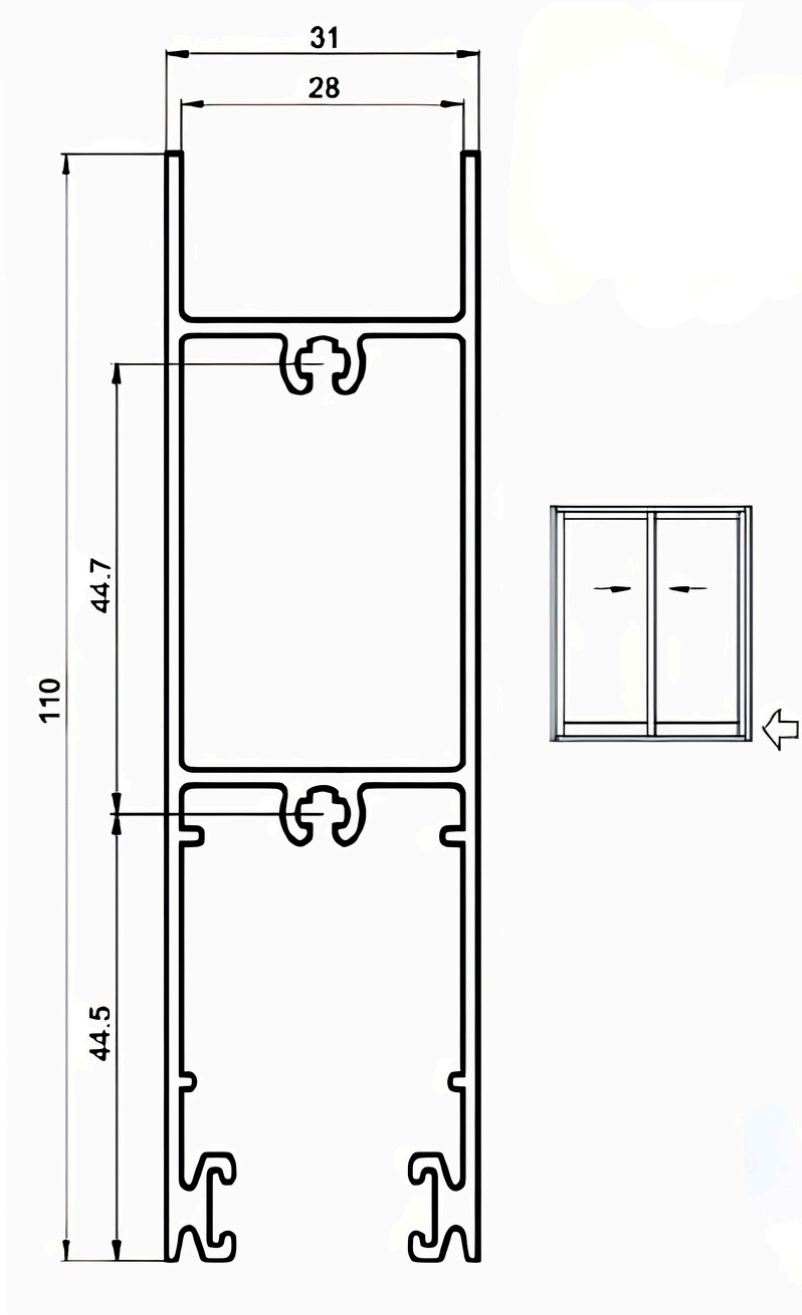

KS
674

Zocalo Corrediza DVH

(1,412 kg/m)
Tiras por Paquete 2

MTX



LA MEJOR CALIDAD PARA UN
MUNDO DE POSIBILIDADES

INGRESA
EN NUESTRA
PÁGINA WEB



mtxperfiles.com/ 

 @MTXPERFILES



+54 9 11 2699-6231
+54 9 11 3081-9410
+54 9 11 5338-8537